



Bachelor of Social Sciences (Honours) in Sociology and Community Studies (Two-year Full-time)

When Communities Meet Sociology...

Prof CHIU Wing Kai Stephen
Chair Professor of Sociology



Stephen Wing-Kai Chiu

趙永佳

Chair Professor Sociology

Associate Dean

Faculty of Liberal Arts and Social Sciences

The Education University of Hong Kong



What is Sociology???



DAILY NEWS

World - Business - Finance - Lifestyle - Travel - Sport - Weather

Issue: 240104

THE WORLDS BEST SELLING NATIONAL NEWSPAPER

Est - 1965

First Edition

Monday 5th June



Sociological imagination is ...



Private troubles



Public issues





相信很多通識教師跟我一樣，有一個不知是好還是壞的習慣，就是每次看報紙都會習慣性把某些新聞變成模擬通識科試題，最近看到《明報》的一則新聞，就「試」與大作地擬了以下一問題：

一人一個

大學夢

資料 A

細閱以下資料：
試場外調查文憑試考生如何計劃出路

註：可選多項

資料來源：〈文憑試考生升大信心一半平 過半指對學士出國「賞假險」〉，《明報》，2012.04.23

出路	人數 (百分比)
八大升學	204 (68%)
副學位	104 (34%)
海外升學	68 (22%)
重讀	44 (14%)
求職	37 (12%)
訪問人數	300

資料 B

教資會資助大學第一年學士學位課程學生人數 (1965/66至2010/11年)

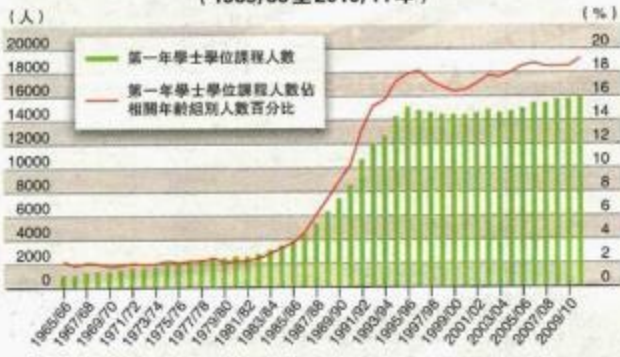

題目：(a) 描述資料 A 所顯示的文憑試考生的出路安排計劃。
(b) 參考資料 B，分析資料 A 所揭示的考生出路計劃是否可行？

這當然不是什麼好題目，因為資料 B 的資料太多，而相關的只有歷史期的資料，不過以下討論會用上這些數據，所以把歷史數據也一併奉上；而且問題也有立場，因為我覺得 68% 的同學在八大升學的願望明顯和現實有距離，而八大升學的人數的 19%，換句話說，有 49% 同學會失望。此外，在《明報》調查中，大部分考生對達到「3322」成績只有一半信心，卻仍期望升讀八大。

當作試題的編過了，上述有幾青年升學的資料與報章卻值得我們深思：學生的願望與學校的衝突，要如何處理？學生作為教育制度內的「玩家」，又應該採取什麼策略？

大學學額求過於供

在討論這個問題之前，且得多看一段相關報道：有青年團體於 2010 年對未來考生展開調查，發現受訪者對「追求更高學歷」的意欲非常高，超過五成 (52.9%) 考生希望能達到學士或碩士以上學歷，只求有中五程度者只佔極少數。

由此看來，相信新高中畢生的學生依然會以升讀更高程度的課程為目標，而當中又以能升讀八大資助院校學位課程為主流。剩下的香港，目標由升讀升讀大學好像理所當然：就算不能立刻升讀大學，或升讀資助大學，也會先報讀副學位課程，博取機會讀大學。其他升學課程，好像高等文憑或其他職業訓練課程就不太受歡迎。家長在這方面的傾向更明顯：我最近並多個家長文

的交集中分析」。對高中通識科同學來說，當下最重要的生命歷程莫過於升學。對大部分同學來說，否還是為了爭取更好成績，期望將來可以升讀理想學校和科目。但大家有沒有想到，升學這個看來理所當然的生命歷程，其實正是社會與歷史交織下影響的結果？我們是否也應該以多角度思考來分析升學這個非常重要的個人成長階段？

社會條件經濟結構改變

在分析之前，先來說說故事。時光倒流 40 年，我在 1970 年代讀過中學階段，如果你調查當時中學生的升學目標，相信結果會和現在截然不同——那時認為自己會念大學的人大概沒很多個——那是因為人在不同社會條件下，個人成長歷程可以有非常大的差異。

首先，當時對很多人來說，「升讀中學」並不是人人都能達到的目標。那時候沒有「九年免費教育」，而且還要考「升中試」來決定誰可以升上中學。升中試是暗？就是要小六學生考中文、數三科，一方面以總成績來決定學生是否能升讀中學，另一方面把合資格的同學按成績派到不同中學。當時我的成績勉強而升中，不過就靠那區區分到還有剩餘學額的地區。於是住在旺角的我，在未有地鐵的時代，就湧到算是「偏遠」的慈雲山小學。

當時的我可算羨且羨：一方面我是家族中第一個升讀中學的成員（父母長輩都只有小學學歷），也是同班同學中唯一能升中的（他們都去「打工」）；

這樣說來好像不滿意，是理所當然的一件事，但當時的我有多幸運，大家可以看看資料 B：要知道在 1980 年代初，能升讀大學的青年只有 2%！大學入學率只有 2% 是什麼一回事？假設一間中學有 5 班，以 200 人來計算，當中能進大學的只有 4 人。那個年代就算能升上預科，但能直接考上大學的是少數，反而重考大學才是普遍現象；我就有一個同學考了 3 次才能考上港大。事實上，在我進了港大後，像我這類家庭背景出身（非名校中學、父母只有小學學歷、收入屬低下階層）的也是極少數。

那麼，那些上不到大學的「大多數」，又是怎麼樣？例如我「那幾年」的死者，都是成績平平的「波生」，會考後大部分出來找工作，其中一人就是後來「TVB 五虎」之一的黃日華（他當年的選擇就是足球員或演員）；據說當年仍在東九龍念中學，會考後進入 TVB 藝員訓練班的還有劉德華。

1970 年代的香港經濟正值黃金時期，勞工市場相當緊張，手持中學「文憑」便可找到一份不錯的工作；有的找到白領文員工作，有的從事銷售，最好的當然是考進政府、銀行或大機構工作。當然，那時大學畢業生的市場處境更好，但就算是中學畢業，也可以找到安穩工作。

話說回來，把中學的日子都挖出來，是想帶出一點，雖然身分一樣，同是念中學的年輕人，但生在 70 年代和生在今天，在不同的教育制度和經濟結構的配合下，我們那一代和今天這一代走上完全不同的成長路，體驗的生命歷程自然有分別。從這個角度看來，升學與就業，其實不是個

加上大學聯招的那班「感不可思議」的同學，個別下能升讀預科升讀大學。

然而，雖然升讀，但勞工市場增長緩慢，不少工潮失業時有所聞，擁有碩士學位的前到工作，於是去請做。這個案當然的失業率並非非學業生，又有幾

呂大樂曾在港香港一般人心目一，「大量人士」，「今天香港」，「雖然沒有減少，但畢業生」，「卻增加」，「兩極化局面」：少作，「一般」畢是預科畢業生為作的學系內一份五、預科畢業生業生來爭取。這與教育制度等社對這些改變，有時

Actual First-year-first-degree (FYFD) Intake Places of UGC-funded Programmes 1965/66 to 2020/21

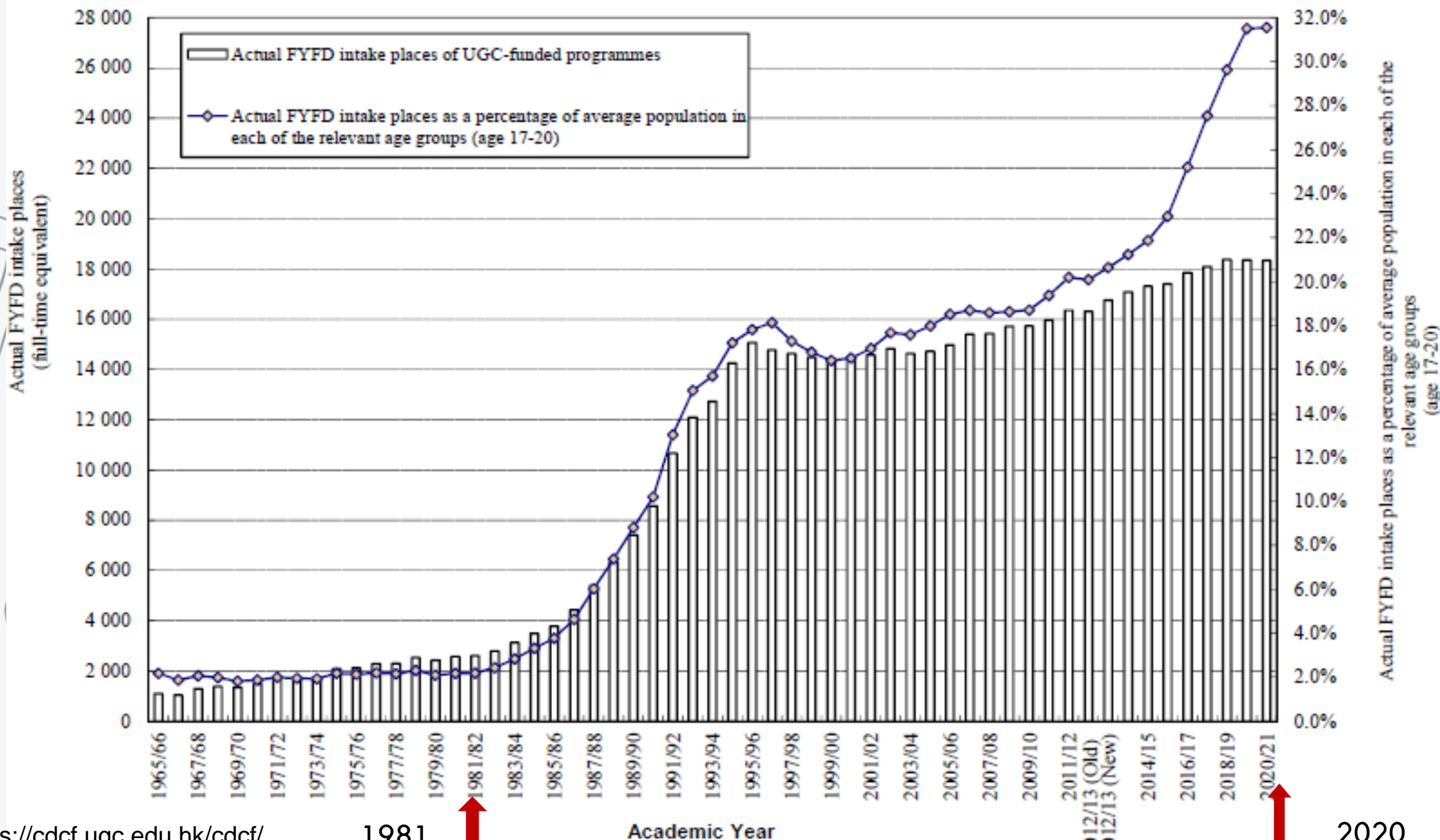

非學位課程

2.1%

毅進文憑／工藝程度

4.2%

文憑／證書課程

20.3%

高級（專業）證書／文憑課程
及副學士／副學士先修等課程

從非學位課程升讀：
10.5%（佔「高中生」的比例）

高中生

直接升讀：42.3%

大學學位課程

31.2%

沒有升學

8.8%

（佔「高中生」的比例）

以不同途徑
提升職業技能

文 × 趙永佳 (<http://liberal-snapshots.blogspot.hk/>)

《來自星星》的通識意義



過去一陣子，香港的負面消息甚多，我和很多人一樣，逃避這些負面情緒的方法是「煲劇」。於是上星期我狠下心來「煲」完了剛播完的韓劇《來自星星的你》。

在播放期間，《星星》完全是一社會現象，每天的娛樂版都在大幅報道，大結局前幾天更已經在描述結局是大團圓，好讓粉絲們放心。到了早前「兩會」期間，中央領導人王岐山公開「表白」他也在看《星星》，令本劇不但稱霸娛樂版，也上了中國版，甚至蔓延港聞。

互聯網的威力，在《星星》中表露無遺，但其實對其他電視節目的傳播作用，在粉絲群中也已是心中有數。熱門的節目在節目播放之後，大概一兩天之內，都會有（偉大的）字幕組大人把字幕弄好，並找來片源，將兩者以「外掛」或「內嵌」方式同步後，上載至網站以BT、網盤或視頻途徑給粉絲們「學習之用」。字幕組大人們的無私奉獻與無償勞動，對我國人民（包括香港）的資訊與娛樂的全球化與對無線電視霸權的打擊，其實比王維基更厲害。我在很多內地論壇網

（那時還未有Yes），流行曲的偶像是中森明菜、小泉今日子（最近在《海女》中重逢、不勝唏噓）、安全地帶，當然還有《龍珠》等動漫。到了2000年後，從《東大特訓班》開始被日劇俘虜，每星期都會上網update一次有沒有新作「全集打包」。後來驚豔於《官僚們的夏天》及《派遣員的品格》等社會派日劇，就積極以日劇作教學材料。近年雖然韓劇情行走俏，但我還是堅持對日劇效忠，不過今次終於「失守」了。

情都可以和全球化扯上關係，但我今次要扯上的全球化關係可不是人云亦云的「韓流襲地球」般的老套。我想說的是，《星星》是一個只有在全球化時代才可能發生的故事。

我還記得我在八十年代中到美國留學，和那時的女友（現在的老妻）分隔兩地。那時要互通款曲，只有兩個辦法，一是長途電話，但那時的長途電話費超貴，我的室友每天都打電話給在香港的女友，整月下來，電話費有時達四百多美元（我們當時的港幣全只有



WHAT IS ROMANCE?



ROMANTIC BAND-AID?!



《城市獵人》



《來自星星的你》



《聽見你的聲音》

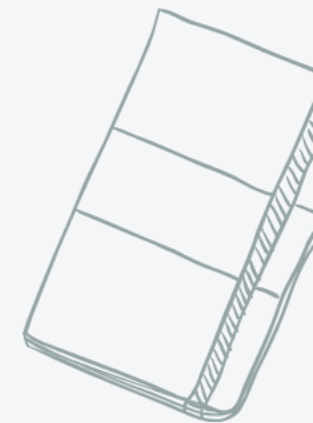



《女人漫畫皮鞋》



《IDO, IDO》



《清潭洞愛麗絲》

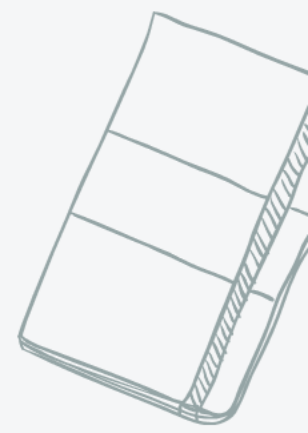

Globalization of Romances?



《深深地戀愛》

石原聰美

綾野剛



When Communities Meet Sociology



Community x Sociology



Individual Level

When was the last time you chatted with your neighbor?

If you are going to bring your friends to visit your community, where would you take them to visit?



Local Level

In your impression, are the playgrounds in your community fun to play?

When was the last time you involved in a community event?



西環變幻時

Public group · 100.7K members

將軍澳主場

Private group · 127.1K members

大埔 TAI PO

Public group · 64.8K members

Regional and Global Level



Do you feel you belong to any regional or global communities?

What would you do for the community?



BTS - "Permission to Dance" performed at the United Nations General Assembly | SD...
United Nations · 33M views · 1 month ago

Zara Jackson 2 小時前
The presence of different languages in the comments shows that love can connect us all! ❤️
👍 9 🔄 回覆

How about a new program?



Programme Features



Curriculum Design

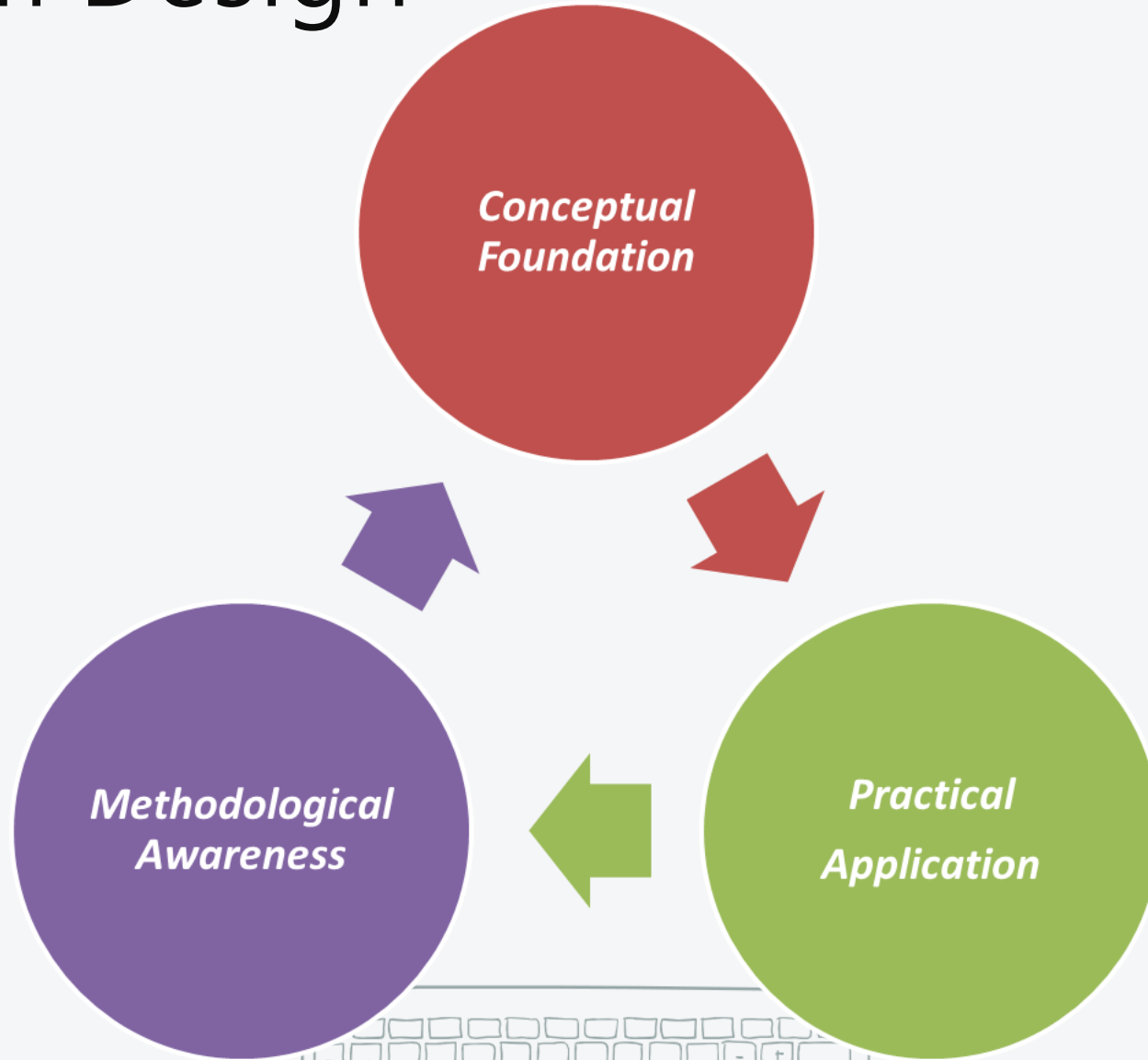

Curriculum Design

(1) Sociology-based Conceptual Foundation

*Conceptual
Foundation*

- Familiarize students with **key concepts** considered as the building blocks of **sociological analyses**.

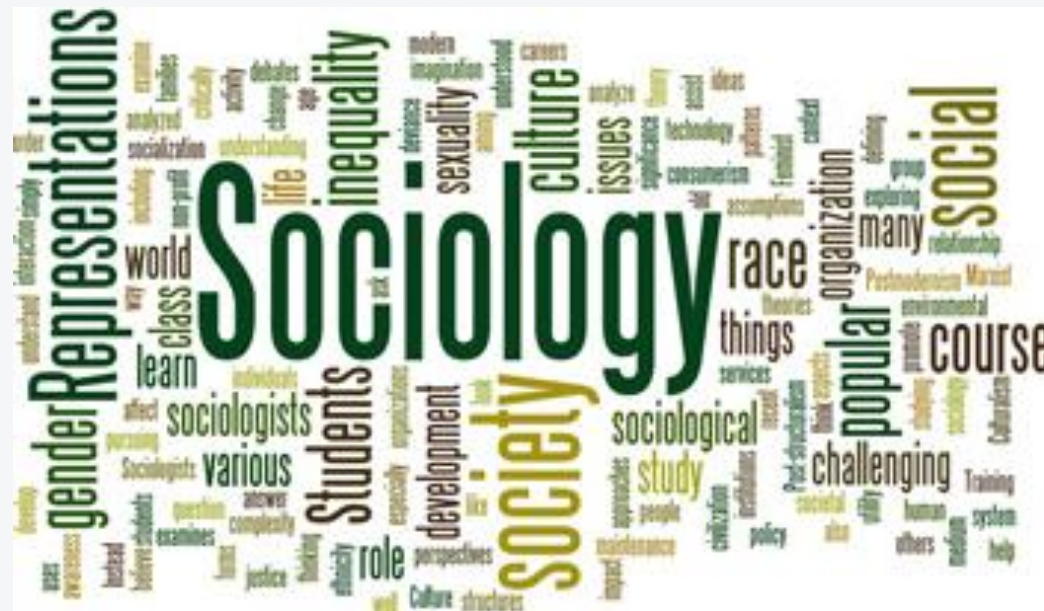

Curriculum Design

(2) Methodological Awareness

*Methodological
Awareness*

Honours
Project I:
Introduction
to Social
Research

Qualitative
Research
Methods

Quantitative
Research
Methods

Honours
Project II:
Research
Report





Curriculum Design

(3) Practical Application

*Practical
Application*

- Provide ample opportunities for students to **link their sociological knowledge with different community concerns and opportunities.**



Internship Partners of SSC



Social Service Non-governmental Organisations (NGOs)



Environmental NGOs



Social Enterprise



Business Sector



Education Sector



Two Optional Minors

Education and Society

Introduces the linkage between **education, social development and ethics**

Sustainable Tourism

Introduces the linkage between **the environment, community development and the tourist sector**



Academic Mentorship

Proactive Mentoring Scheme



- Help students **develop a clear vision and plan** of their study and career in the academic and societal context
 - Mentor get to know mentees by teaching an orientation course to the programme and oversee their progress over 2 years
- 





Career training

Develop skill sets

- Provide a variety of talk and workshop to let student learn by doing
- Help students develop **soft and hard skills** to make contribution in the future career



Local and GBA fieldtrips

Learn about **history**, **culture** and **development** of the place.



Visited The Mills
(Sem1, Oct 2022)



Planned 2-days fieldtrip in
Guangzhou (Sem 2, 2023)

Global Learning Enhancement Fund (GLEF)

All with **\$10,000 subsidy** facilitates students in participating in cross-cultural outreach activities



Career Prospects



Learn, Reflect and Decide on Your Future Pathways



Community-related
Careers



Diverse Career
Options



Educational Careers
via PGDE

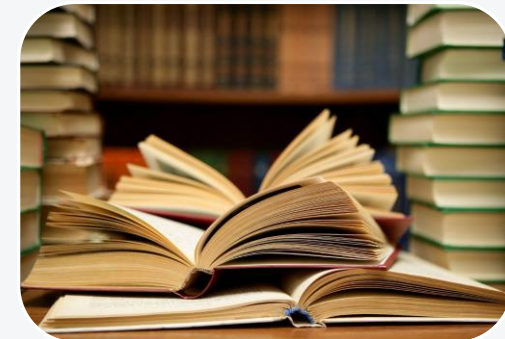

Further Studies for
Professional or
Academic Pathways

University as Adventure -- Let's Go!



Department of Social Sciences and Policy Studies

Merged and renamed in July 2023

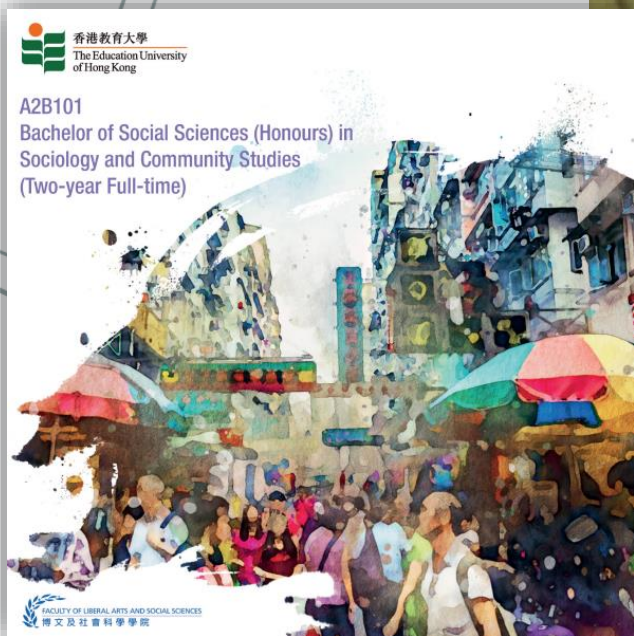

**Sociology and
Community Studies**



This programme will be offered under the new “Department of Social Sciences and Policy Studies” effective from 2023/24.



**Social Entrepreneurship and
Developmental Studies**



香港教育大學
The Education University
of Hong Kong

A2B101
Bachelor of Social Sciences (Honours) in
Sociology and Community Studies
(Two-year Full-time)



FACULTY OF LIBERAL ARTS AND SOCIAL SCIENCES
博文及社會科學學院

More information
on the programme's webpage:
[https://www.apply.eduhk.hk/ug/
programmes/scs](https://www.apply.eduhk.hk/ug/programmes/scs)



Follow our Facebook and Instagram



Facebook:
Sociology and Community
Studies/SCS.EdUHK



Instagram:
eduhkscs



香港教育大學

The Education University
of Hong Kong

A2B101

Bachelor of Social Sciences (Honours) in
Sociology and Community Studies
(Two-year Full-time)



FACULTY OF LIBERAL ARTS AND SOCIAL SCIENCES
博文及社會科學學院



questions and queries?

Admission-related

Tel: (852) 2948 6886

Email: admission@eduhk.hk

Programme-related

Tel: (852) 2948 7707

Email: jclee@eduhk.hk (Ms. Lee)

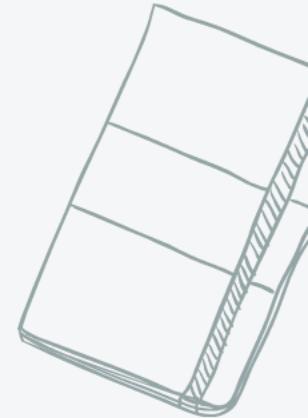

Bachelor of Social Sciences (Honours) in Sociology and Community Studies



Q&A